

Pre-Production



FCe™ 100F Fuel Cell Engine

The Leading Fuel Cell Engine for Commercial Vehicles

Purposed-built for MD/HD vehicles shock and vibration environment

Combustion-Less Engine providing Zero Emission Electric Power

The 100kW Fuel Cell engine is our most robust engine with 40 kW/sec transient power capabilities offering a fully integrated freeze capable system with a rapid startup design and industry leading power density specifically designed for medium and heavy duty, transit bus, drayage trucks, GSE, ports and logistics equipment and off-road applications.

Performance Characteristics

● Electrical

Output Power‡	15 - 100kW
Output voltage	375 - 750V _{DC} (Integrated Isolated dc-dc converter)
Ramp rate	40 kW/sec

● Efficiency

System Efficiency†	58.3 to 46% (10% to full power)
--------------------	---------------------------------

● Temperature

Ambient Temperature	-30 to 50°C
Cooling Inlet	-30 to 57°C (50/50 WEG)

● Fuel

Fuel Flow	6.25 kg/hr @ full power
Fuel Pressure	1200 ±200 kPa _g
Fuel Type	SAE J2719 Hydrogen

● Physical Characteristics

Dimensions (L x W x H)	916 x 879 x 614 mm
Weight	238 kg, (288 kg including Isolated dc-dc converter)



● Interface

Vehicle Communications	CAN SAE J1939
------------------------	---------------

● Startup / Shutdown

Startup Time	30 seconds
Startup from Frozen Time	5 minutes to thaw, 60sec to initial power
Shutdown Time	10 seconds

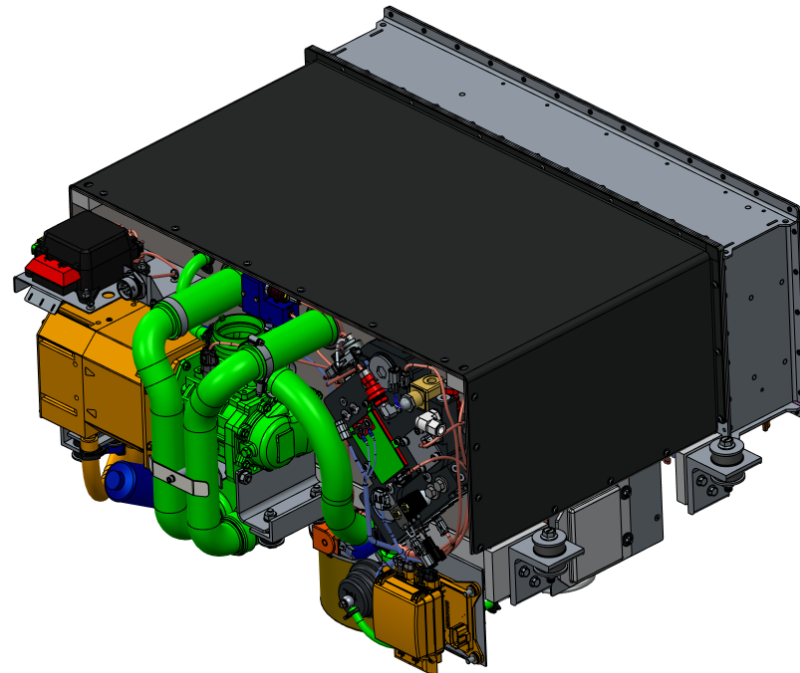

US Hybrid

FCe™ 100F Fuel Cell Engine

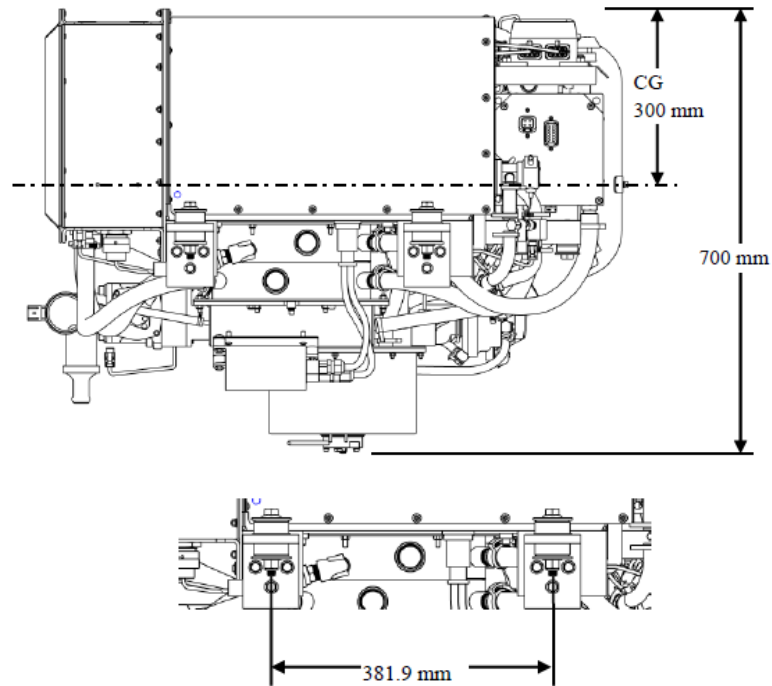
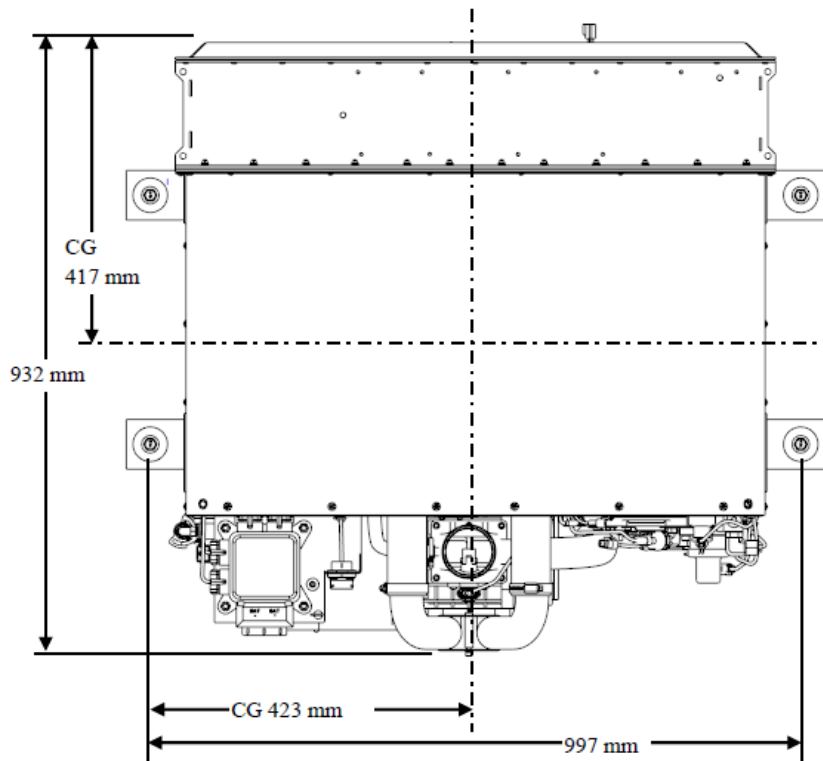

Detail same on both sides.
Mounting locations in 4 places, use M12X1.75 bolts each.

FCe™100 is an integrated fuel cell engine that is purposed-built for heavy-duty vehicles meeting SAE J1455 shock and vibration and environmental requirement. The FC engine includes the integrated dc-dc converter and the safety disconnect and protection system with high voltage isolations.

The FCe™100 engine is the most efficient fuel cell engine with all BOP components integrated and no demand from the vehicle. The low-pressure operation allows fast transient response with high efficiency even at low power range. The FC engine design allow ease with installation, command and control similar to conventional engine. Cooling is 50/50 WEG system with no external DI water-cooling or circulation pump

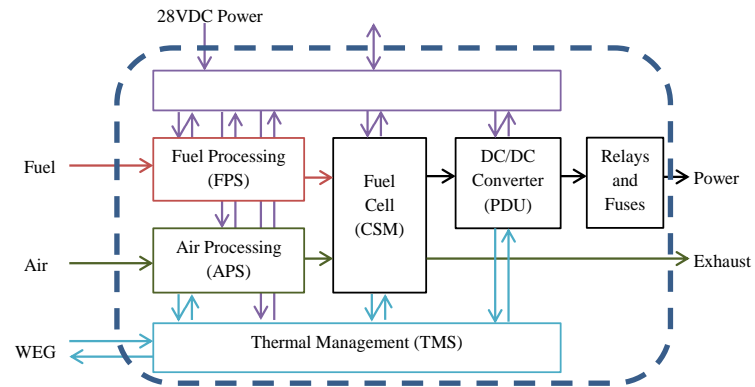

FCe™100 Integrated FC engine diagram

† System efficiency represents energy delivered per energy fed in the form of hydrogen (calculated on a LHV basis).

‡ Full power is the maximum power the electric engine can continuously deliver.



445 Maple Ave. Torrance, CA 90503, USA • 175 Governor's Highway South Windsor, CT 06074 USA

Integrated Components Solutions for Clean Mobility & Energy Conservation

www.ushybrid.com

US Hybrid

FCe™100F
Fuel Cell Engine