

Pre-Production



# FCe™ 50F Fuel Cell Engine

## The Leading Fuel Cell Engine for Commercial Vehicles

Purposed-built for medium duty vehicles shock and vibration environment

### Combustion-Less Engine providing Zero Emission Electric Power

The 50kW Fuel Cell engine is our most robust engine with 20 kW/sec transient power capabilities offering a fully integrated freeze capable system with a rapid startup design and industry leading power density specifically designed for medium duty, shuttle bus, port trucks, GSE, ports and logistics equipment and off-road applications.

### Performance Characteristics

#### ● Electrical

Output Power‡	5 - 50kW
Output voltage	300 - 750V <sub>DC</sub> (Integrated dc-dc converter)
Ramp rate	20 kW/sec

#### ● Efficiency

System Efficiency†	56.9 to 46.3% (10% to full power)
--------------------	-----------------------------------

#### ● Temperature

Ambient Temperature	-40 to 55°C
Cooling Inlet	Up to 60°C (50/50 WEG)

#### ● Fuel

Fuel Flow	3.0 kg/hr @ full power
Fuel Pressure	1200 ±200 kPa <sub>g</sub>
Fuel Type	SAE J2719 Hydrogen

#### ● Physical Characteristics

Dimensions (L x W x H)	993 x 455 x 692 mm
Weight	148 kg, (including Isolated dc-dc converter)



#### ● Interface

Vehicle Communications	CAN SAE J1939
------------------------	---------------

#### ● Startup / Shutdown

Startup Time	10 seconds
Startup from Frozen Time	3 minutes
Shutdown Time	30 seconds

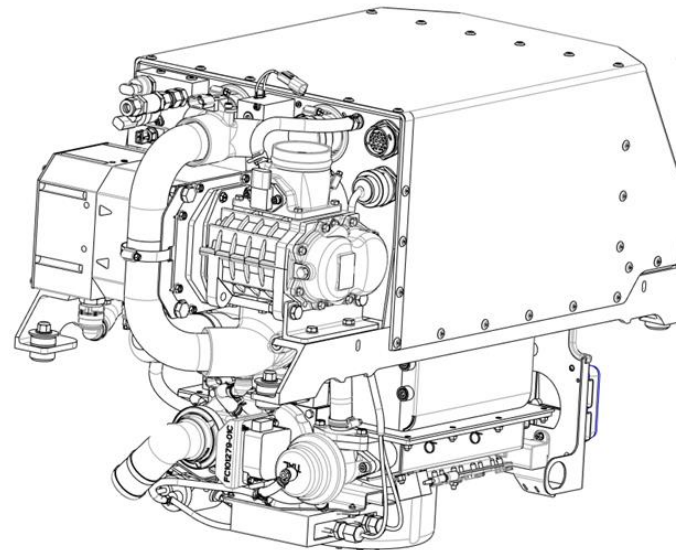

US Hybrid

FCe™ 50F  
Fuel Cell Engine

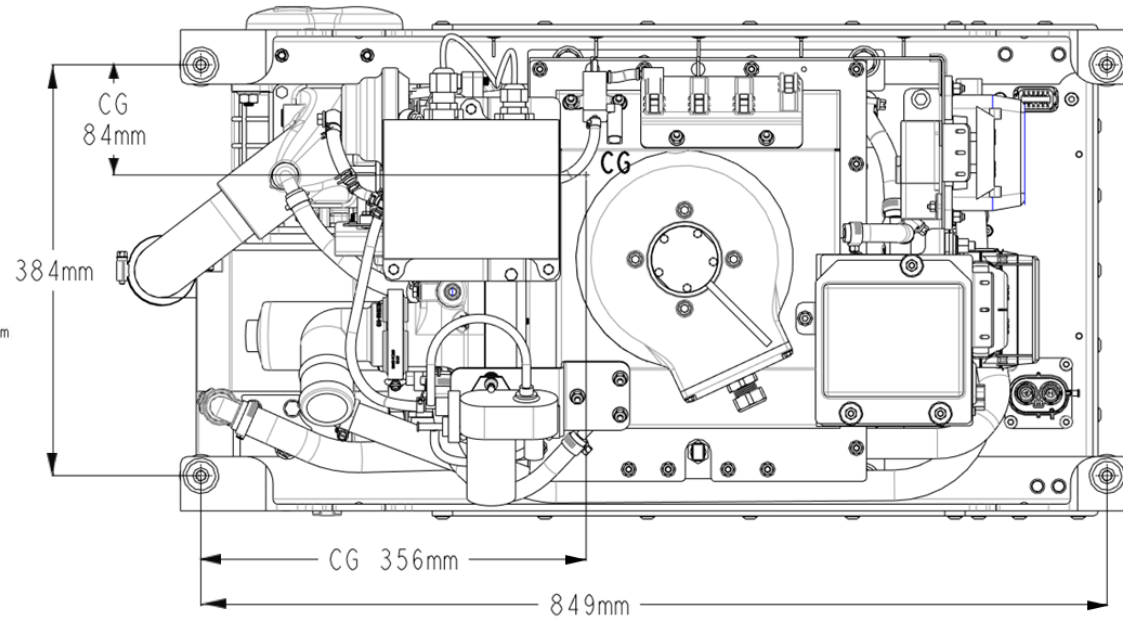
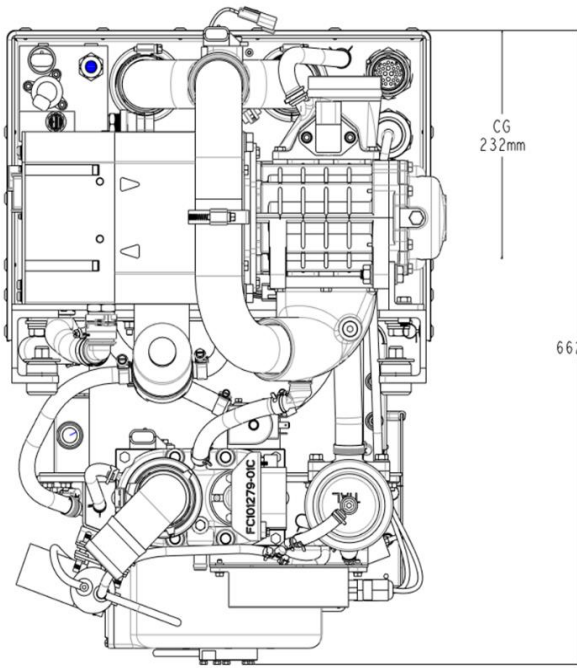

FCe™50 is an integrated fuel cell engine that is purpose-built for medium-duty vehicles meeting SAE J1455 shock and vibration and environmental requirement. The FC engine includes the integrated dc-dc converter and the safety disconnect and protection system.

The FCe™50 engine is the most efficient fuel cell engine with all BOP components integrated and no demand from the vehicle. The low-pressure operation allows fast transient response with high efficiency even at low power range. The FC engine design allows easy installation, command and control as a conventional engine. Cooling is 50/50 WEG system with no external DI water-cooling or circulation pump

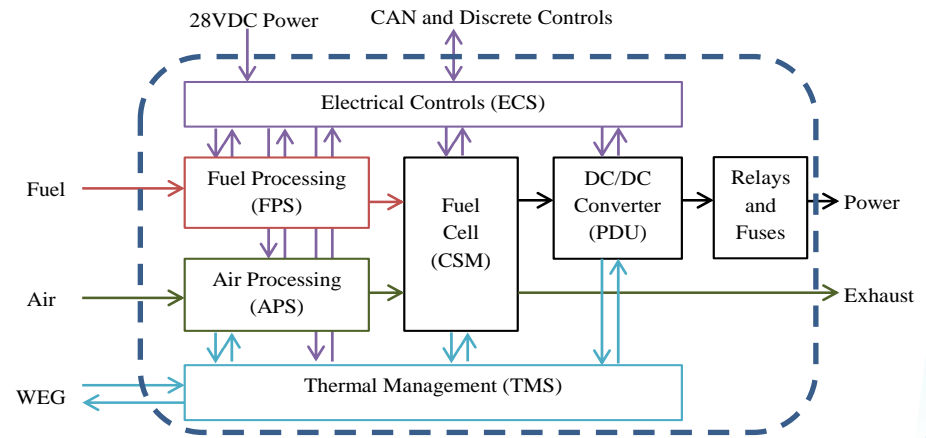

FCe™50 Integrated FC engine diagram

† System efficiency represents energy delivered per energy fed in the form of hydrogen (calculated on a LHV basis).

‡ Full power is the maximum power the electric engine can continuously deliver.

US Hybrid reserves the right to change the specification without notice. Rev: 191104



445 Maple Ave. Torrance, CA 90503, USA • 175 Governor's Highway South Windsor, CT 06074 USA

Integrated Components Solutions for Clean Mobility & Energy Conservation

www.ushybrid.com